

Magnetic Inductive Flowmeter

for Conductive Liquids, Slurries, or Pastes



measuring
•
monitoring
•
analyzing

EPS / UMF2



- High Accuracy:
0.3 % of Measured Value \pm 0.01 % * (Q at 10 m/s)
(Under Reference Conditions)
- Maintenance-free
- No Pressure Drop
- Wide Variety of Lining and Electrode Materials



KOBOLD companies worldwide:

AUSTRALIA, AUSTRIA, BELGIUM, BULGARIA, CANADA, CHINA, CZECHIA, FRANCE, GERMANY, GREAT BRITAIN, HUNGARY, INDIA, INDONESIA, ITALY, MALAYSIA, MEXICO, NETHERLANDS, PERU, POLAND, REPUBLIC OF KOREA, RUSSIA, SPAIN, SWITZERLAND, THAILAND, TUNISIA, TURKEY, USA, VIETNAM

KOBOLD Instruments, Inc.
1801 Parkway View Drive
Pittsburgh, PA 15205
☎ Main Office:
1.800.998.1020
☎ 1.412.788.4890
info@koboldusa.com
www.koboldusa.com



Description

The EPS magnetic-inductive flow sensor is used to measure the volumetric flow of liquids, slurries, pastes and other electrically conductive media without any pressure drop. Pressure, temperature, density and viscosity do not affect the volume measurements. Solid particles and small gas bubbles should be avoided. The EPS sensor can be used in combination with the KOBOLD UMF2 transmitter. The transmitter is available in a compact version or a remote version.

Operation

An electrically conductive media flowing through a magnetic field, in accordance to Faraday's law of induction, will induce a voltage proportional to the mean flow velocity rate and hence the volumetric flow. A magnetic inductive flowmeter consists of a lined flow body, through which a conductive liquid flows, a magnetic field coil and two electrodes. The electrode voltage is detected by a transmitter and converted into standardized electrical signal such as 4-20 mA or pulse output.

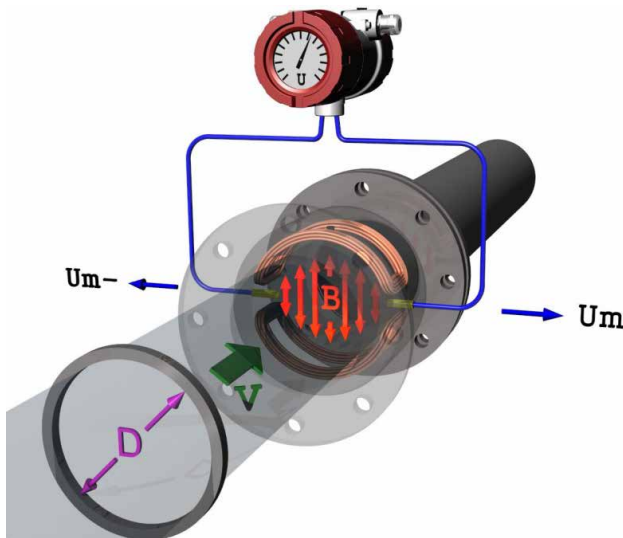

Advantages

- Wide Variety of Lining Materials
- Electrodes in Stainless Steel, Hastelloy® C276, Tantalum, Platinum-Iridium, Titanium
- Large Selection of Process Connections
- For Use in Harsh Environments

Technical Details for EPS Sensor



Flow Body:	Painted Steel (Standard), Stainless Steel Tri-Clamp®, Ceramic Models
Nominal Sizes:	1/12", 1/8", 1/4", 3/8" Inside Diameter Process Connection in 1/2" NPT, ANSI 1/2" ... 24" (Other Nominal Sizes on Request)
Connection:	Flanges of Steel or 304 Stainless Steel (ASME B16.5), 1/2" NPT of 316L Stainless Steel or Hastelloy®, or Tri-Clamp® (Other Connections on Request)
Lining Material:	Hard Rubber, Soft Rubber, EPDM, PTFE, or Ceramic
Electrode Material:	316-Ti Stainless Steel, Hastelloy® C276, Titanium, Tantalum or Platinum-Iridium
Nominal Pressure (ANSI Flange) per ASME B16.5: (verify flange material, rating, & temperature)	
1/2" to 24":	Class 150, 230 PSI
1/2" to 12":	Class 300, 580 PSI (Higher Pressures on Request)
Process Temperature:	
EPDM Lining:	14...158 °F
PTFE Lining:	-4...302 °F
Ceramic Lining	
w/ EPDM Gaskets:	-4...302 °F
w/ PTFE Gaskets:	-4...266 °F
Hard Rubber:	32...203 °F
Soft Rubber:	32...158 °F
Ambient Temp:	-4...140 °F, Depending on Process Temperature
Conductivity:	≥ 5 μS/cm ≥ 20 μS/cm with Demineralized Water
Measuring Ranges:	0.5 m/s ... 10 m/s
Accuracy:	± 0.3 % of Measured Value ± 0.01 % * (Q at 10 m/s) (Under Reference Conditions)
Repeatability:	± 0.15 % of Measured Value ± 0.005 % * (Q at 10 m/s) (Under Reference Conditions)
Protection:	IP67 (EN60529), IP68

Flow Ranges

Inner Diameter of Measuring Tube	Connection Size	GPM	
		Q _{min}	Q _{max}
1/12"	1/2"	0.03	0.49
1/8"	1/2"	0.06	1.11
1/4"	1/2"	0.23	4.48
3/8"	1/2"	0.63	12.4
1/2"	1/2"	1.47	29.0
1"	1"	4.21	84.0
1-1/2"	1-1/2"	8.5	168.0
2"	2"	15.5	309.0
3"	3"	38.0	747.0
4"	4"	61.0	1,205
6"	6"	140	2,780
8"	8"	245	4,890
10"	10"	395	7,865
12"	12"	565	11,270
14"	14"	705	14,050
16"	16"	925	18,450
18"	18"	1,170	23,375
20"	20"	1,470	29,360
24"	24"	2,110	42,115

Accuracy/Repeatability

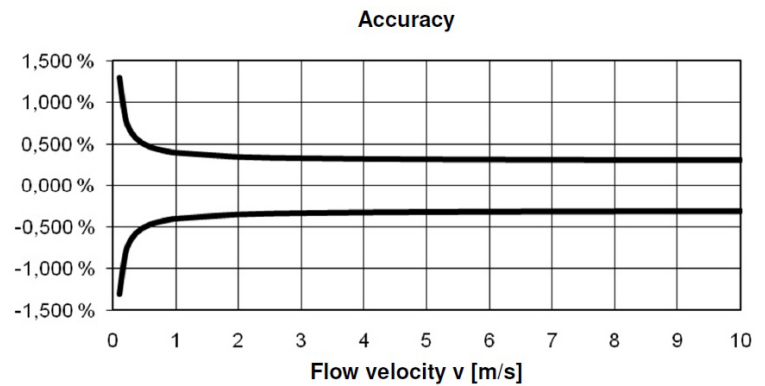

Accuracy: ±0.3% of Measured Value + 0.0001 * (Q at 10 m/s)

Repeatability: ±(0.15% of Measured Value + 0.00005 * (Q at 10 m/s))

Material Load Curve

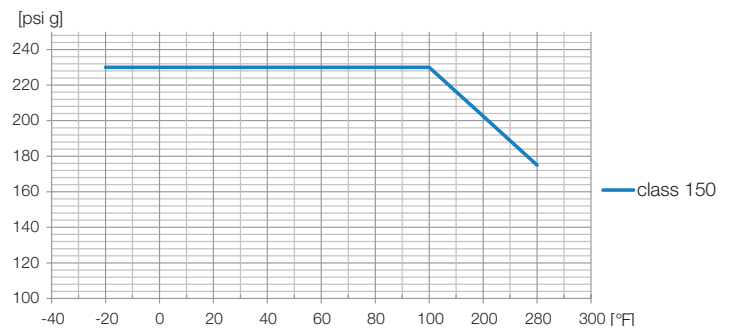

For stainless steel flanges (1.4404 / 316L) according to ASME B16.5

Technical Details for UMF2 Transmitter



Mounting Options: Compact or Remote
Housing: Die Cast Aluminum, Painted
Power Supply: 115/230 V_{AC} 50/60 Hz, 10 VA
 24 V_{DC} 10 W

Indication: LCD, 2-lines, 16 Digits, Back-lit
Interface Language: English, German
Output
Analog: 4-20 mA, Active, Galvanically Isolated
Pulse: Passive, Galvanically Isolated
 24 V, 60 mA
Status: Passive, Galvanically Isolated
 24 V, 60 mA
Ambient Temp: -4...140 °F (-20...60 °C),
 Depending on Process Temperature
Protection: IP67 or IP68 (EN60529)
Communication: HART®
Diagnostics: Empty Pipe Detection, Coil Current
 Monitoring
Electromagnetic Tolerance: EMC-Directive 2014/30/EU (EMC)



Magnetic Inductive Flowmeter Model EPS

Order Details for Models EPS-H and EPS-W: Sensor with Hard Rubber (Ebonite) or Soft Rubber Lining

Model Liner Material	Connections*	Process Connection Material	Electrode Material	Grounding Electrode	Transmitter Mounting	Certificates	Transmitter
EPS-H.. = Hard Rubber (Ebonite)	..203R.. = 1" ANSI Class 150*	..1.. = Flange, Steel, Painted ..2.. = Flange 304 SS	..S.. = 316-Ti SS ..H.. = Hastelloy® ..M.. = Titanium	..S.. = 316-Ti SS ..H.. = Hastelloy® ..M.. = Titanium	..1.. = Integrated Transmitter, IP67 ..2.. = Remote Transmitter, IP 67, Terminal Box via M20x1.5, (Cable >10 m, add Junction Box at Transmitter) ..3.. = Remote Transmitter, IP 68, Terminal Box via M20x1.5, Encapsulated (Add Junction Box at Transmitter)	..0 = without ..1 = Certificate of Compliance with Order 2.1 ..2 = Test Report 2.2 ..B = Inspection/ Material Certificate 3.1 DIN/ EN10204:2008 ..C = Inspection/ Material Certificate 3.2 DIN/ EN10204:2008	To Complete the Order, Refer to the Order Table on Page Six to Order Transmitter UMF2
	..205R.. = 1-1/2" ANSI Class 150*						
	..206R.. = 2" ANSI Class 150*						
	..208R.. = 3" ANSI Class 150*						
	..210R.. = 4" ANSI Class 150*						
	..212R.. = 6" ANSI Class 150*						
	..213R.. = 8" ANSI Class 150*						
EPS-W.. = Soft Rubber	..214R.. = 10" ANSI Class 150*	..S.. = 316-Ti SS ..H.. = Hastelloy® ..T.. = Tantalum ..N.. = Platinum/Iridium	..S.. = 316-Ti SS ..H.. = Hastelloy® ..T.. = Tantalum ..N.. = Platinum/Iridium	..S.. = 316-Ti SS ..H.. = Hastelloy® ..T.. = Tantalum ..N.. = Platinum/Iridium	..3.. = Remote Transmitter, IP 68, Terminal Box via M20x1.5, Encapsulated (Add Junction Box at Transmitter)	..0 = without ..1 = Certificate of Compliance with Order 2.1 ..2 = Test Report 2.2 ..B = Inspection/ Material Certificate 3.1 DIN/ EN10204:2008 ..C = Inspection/ Material Certificate 3.2 DIN/ EN10204:2008	To Complete the Order, Refer to the Order Table on Page Six to Order Transmitter UMF2
	..215R.. = 12" ANSI Class 150*						
	..216R.. = 14" ANSI Class 150*						
	..217R.. = 16" ANSI Class 150*						
	..218R.. = 18" ANSI Class 150*						
..219R.. = 20" ANSI Class 150*							
..220R.. = 24" ANSI Class 150*							

* 300 LB ANSI available upon request

Order Details for Model EPS-P: Sensor with PTFE Lining

Model Liner Material	Connections	Process Connection Material	Electrode Material	Grounding Electrode	Transmitter Mounting	Certificates	Transmitter
EPS -P.. = PTFE	..201R.. = 1/2" ANSI Class 150	..1.. = Flange, Steel, Painted ..2.. = Flange 304 SS	..H.. = Hastelloy® ..T.. = Tantalum ..N.. = Platinum/Iridium ..M.. = Titanium	..H.. = Hastelloy® ..T.. = Tantalum ..N.. = Platinum/Iridium ..M.. = Titanium	..1.. = Integrated Transmitter, IP67 ..2.. = Remote Transmitter, IP67, Terminal Box via M20x1.5, (Cable >10 m, add Junction Box at Transmitter) ..3.. = Remote Transmitter, IP68, Terminal Box via M20x1.5, Encapsulated (Add Junction Box at Transmitter)	..0 = without ..1 = Certificate of Compliance with Order 2.1 ..2 = Test Report 2.2 ..B = Inspection/ Material Certificate 3.1 DIN/ EN10204:2008 ..C = Inspection/ Material Certificate 3.2 DIN/ EN10204:2008	To Complete the Order, Refer to the Order Table on Page Six to Order Transmitter UMF2
	..203R.. = 1" ANSI Class 150						
	..205R.. = 1-1/2" ANSI Class 150						
	..206R.. = 2" ANSI Class 150						
	..208R.. = 3" ANSI Class 150						
	..210R.. = 4" ANSI Class 150						
	..212R.. = 6" ANSI Class 150						
	..213R.. = 8" ANSI Class 150						
	..214R.. = 10" ANSI Class 150						
..215R.. = 12" ANSI Class 150							



Order Details for Model EPS-E: Sensor with EPDM Lining

Model Liner Material	Connections	Process Connection Material	Electrode Material	Grounding Electrode	Transmitter Mounting	Certificates	Transmitter
EPS -E.. = EPDM	..201R.. = 1/2" ANSI Class 150	..1.. = Flange, Steel, Painted	..H.. = Hastelloy®	..H.. = Hastelloy®	..1.. = Integrated Transmitter, IP67 ..2.. = Remote Transmitter, IP 67, Terminal Box via M20x1.5, (Cable >10 m, add Junction Box at Transmitter) ..3.. = Remote Transmitter, IP 68, Terminal Box via M20x1.5, Encapsulated (Add Junction Box at Transmitter)	..0 = without ..1 = Certificate of Compliance with Order 2.1 ..2 = Test Report 2.2 ..B = Inspection/ Material Certificate 3.1 DIN/ EN10204:2008 ..C = Inspection/ Material Certificate 3.2 DIN/ EN10204:2008	To Complete the Order, Refer to the Order Table on Page Six to Order Transmitter UMF2
	..203R.. = 1" ANSI Class 150						
	..205R.. = 1-1/2" ANSI Class 150						
	..206R.. = 2" ANSI Class 150						
	..208R.. = 3" ANSI Class 150						
	..210R.. = 4" ANSI Class 150						
	..212R.. = 6" ANSI Class 150						
	..213R.. = 8" ANSI Class 150						
	..214R.. = 10" ANSI Class 150						
	..215R.. = 12" ANSI Class 150						
	..216R.. = 14" ANSI Class 150						
	..217R.. = 16" ANSI Class 150						
	..218R.. = 18" ANSI Class 150						
..219R.. = 20" ANSI Class 150							
..220R.. = 24" ANSI Class 150							

Order Details for Model EPS-A: Sensor with Ceramic Lining

Model Liner Material	Connection Type, Material, Seal	Electrode Material	Grounding Electrode	Transmitter Mounting	Certificates	Transmitter
EPS-A.. = Ceramic	..002AG.. = 1/2" NPT Male (1/12" I.D.), 316L SS, EPDM	..N.. = Platinum/Iridium	..0.. = without	..1.. = Integrated Transmitter, IP67 ..2.. = Remote Transmitter, IP 67, Terminal Box via M20x1.5, (Cable >10 m, add Junction Box at Transmitter) ..3.. = Remote Transmitter, IP 68, Terminal Box via M20x1.5, Encapsulated (Add Junction Box at Transmitter)	..0 = without ..1 = Certificate of Compliance with Order 2.1 ..2 = Test Report 2.2 ..B = Inspection/ Material Certificate 3.1 DIN/ EN10204:2008 ..C = Inspection/ Material Certificate 3.2 DIN/ EN10204:2008	To Complete the Order, Refer to the Order Table on Page Six to Order Transmitter UMF2
	..003AG.. = 1/2" NPT Male (1/8" I.D.), 316L SS, EPDM					
	..006AG.. = 1/2" NPT Male (1/4" I.D.), 316L SS, EPDM					
	..010AG.. = 1/2" NPT Male (3/8" I.D.), 316L SS, EPDM					
	..H02AN.. = 1/2" NPT Male (1/12" I.D.), Hastelloy®, PTFE					
	..H03AN.. = 1/2" NPT Male (1/8" I.D.), Hastelloy®, PTFE					
	..H06AN.. = 1/2" NPT Male (1/4" I.D.), Hastelloy®, PTFE					
	..H10AN.. = 1/2" NPT Male (3/8" I.D.), Hastelloy®, PTFE					
	..7000G.. = 1/2" Tri-Clamp®, SS					
	..7010G.. = 1" Tri-Clamp®, SS					
	..7020G.. = 1-1/2" Tri-Clamp®, SS					
	..7030G.. = 2" Tri-Clamp®, SS					
	..7050G.. = 3" Tri-Clamp®, SS					
..7060G.. = 4" Tri-Clamp®, SS						



Magnetic Inductive Flowmeter Model EPS

Order Details for UMF2 Transmitter

Model	Mount and Connections	LCD Display	Power Supply	Output Signal	Optional Longer Cable Length (Junction Box)	
UMF2-	..A.. = IP 67, Integral Transmitter, 1/2" NPT					
	..B.. = IP67, Integral Transmitter, M20x1.5				..1 = IP67, 16' (5m), Breakout Cable	
	..C.. = IP67, Remote Transmitter, Includes 2.5 m Cable and C/W Pipe/Wall Mounting Bracket, (Cable > 10 m Add Junction Box at Transmitter), 1/2" NPT				..2 = IP67, 32' (10m), Breakout Cable ..3 = IP67, 49' (15m)	
	..D.. = IP67, Remote Transmitter, Includes 2.5 m Cable and C/W Pipe/Wall Mounting Bracket, (Cable > 10 m Add Junction Box at Transmitter), M20x1.5	..1.. = with	..1.. = 230 V _{AC} (+10%, -15%) 50/60 Hz	..2.. = 115 V _{AC} (+10%, -15%) 50/60 Hz	..F0BK = Current Output of 4-20 mA, Pulse Output Passive U _m = 24 V _{DC} , Status Output Passive U _m = 24 V _{DC}	..4 = IP67, 65' (20m) ..5 = IP67, 98' (30m) ..6 = IP67, 130' (40m) ..7 = IP67, 164' (50m)
	..G.. = IP68, Remote Transmitter, Includes 2.5 m Cable and C/W Pipe/Wall Mounting Bracket, (Transmitter C/W Terminal Connection Box), 1/2" NPT			..4.. = 24 V _{DC} (± 15%)	..G0BK = Current Output of 4-20 mA with HART® Protocol, Pulse Output Passive U _m = 24 V _{DC} , Status Output Passive U _m = 24 V _{DC}	..B = IP68, 16' (5m) ..C = IP68, 32' (10m) ..D = IP68, 49' (15m) ..E = IP68, 65' (20m) ..F = IP68, 98' (30m)
	..H.. = IP68, Remote Transmitter, Includes 2.5 m Cable and C/W Pipe/Wall Mounting Bracket, (Transmitter C/W Terminal Connection Box), M20x1.5					..G = IP68, 130' (40m) ..H = IP68, 164' (50m)

Electrical Connections
Mounting Types

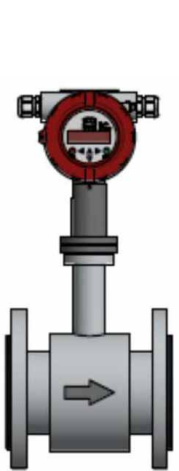

Compact IP67 according to DIN/EN 60529
Dust tight, short time submersible.

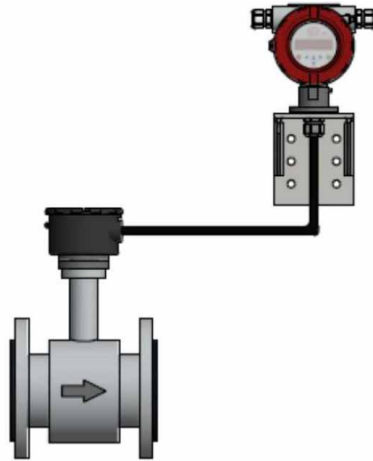

Remote IP67 according to DIN/EN 60529
Dust tight, short time submersible.
(With 2.5 m, 5 m and 10 m factory mounted cable on transmitter.)

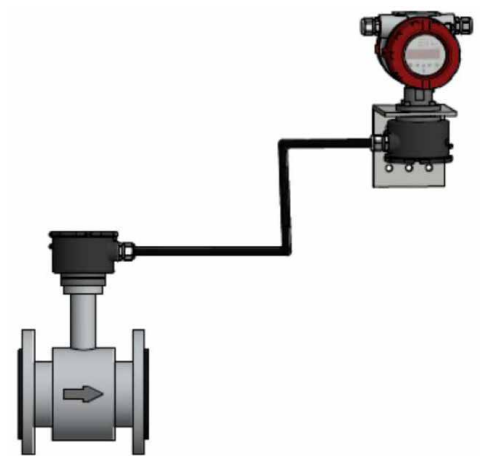

Remote IP68 according to DIN/EN 60529
Dust tight, suitable for continuous immersion.
(For distances >10 m, factory mounted cable on transmitter, junction box on sensor resin filled.)

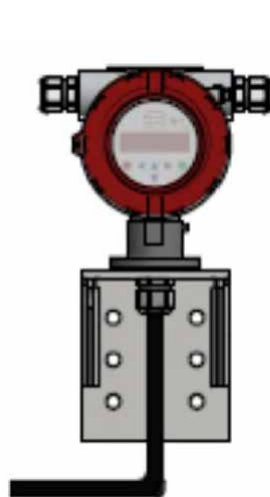

PE
SP- yellow
SP+ green

2 (FE)
1 brown
3 white

Remote version up to 10 m cable

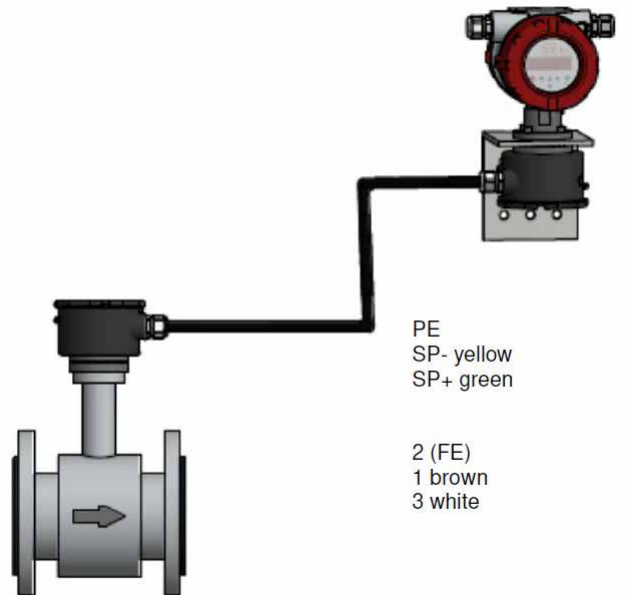

PE
SP- yellow
SP+ green

2 (FE)
1 brown
3 white

Remote version > 10 m cable

Installation Conditions

To avoid vacuum, emptying of pipes, or gas aggregation please take notice of the following mounting advice.

Emptying possible

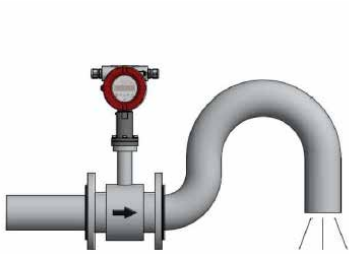

Emptying avoided

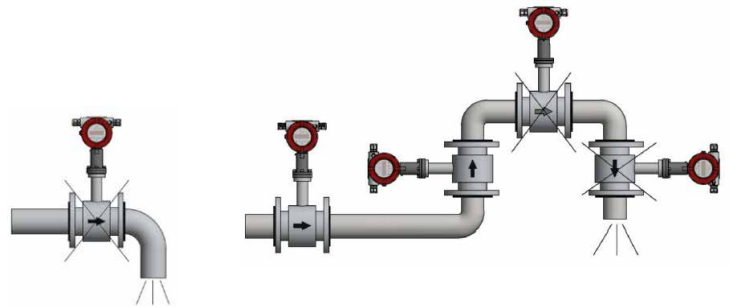

Upstream of pump, vacuum possible



Mount in ascending main

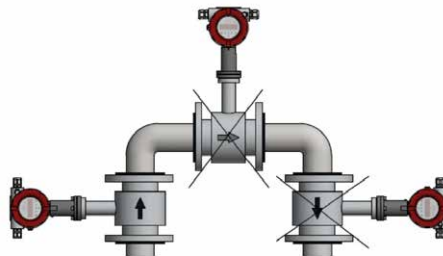

Do not mount downstream of a valve

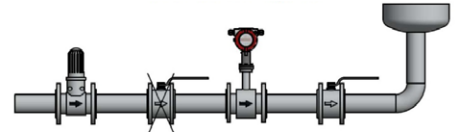

Use support to prevent vibration.

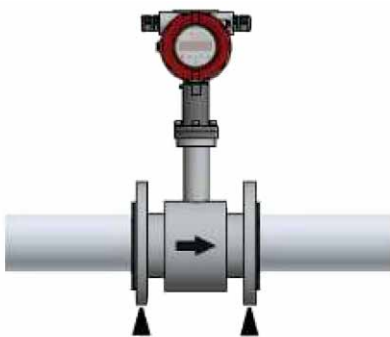

Pipe narrowing with maximum 8° angle

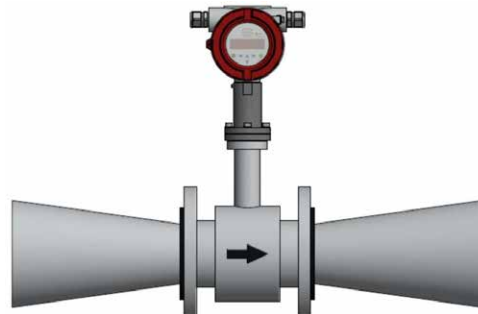

Ambient Conditions

As the flowmeter becomes an element of the piping, they are sometimes thermally insulated when installed to save energy and prevent accidental physical contact. The heat of the process temperature will be transferred through the support neck of the integrally mounted transmitter or terminal box. For this reason the

thermal insulation of the flowmeter should only extend half way up the support of the transmitter. It is essential not to include the transmitter or the terminal box as part of the thermal insulation. The maximum permissible liquid temperature limits are stated on the rating plate of the respective flowmeter version.

Maximum Ambient Temperature According to Media Temperature with a Direct Mounted Transmitter

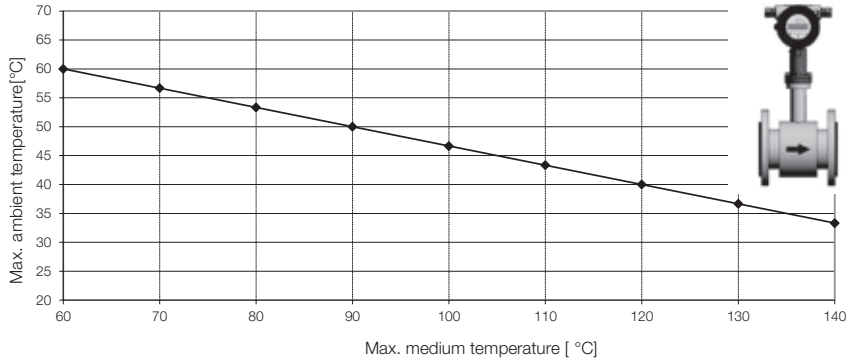

Maximum Ambient Temperature According to Media Temperature with a Mounted Terminal Box

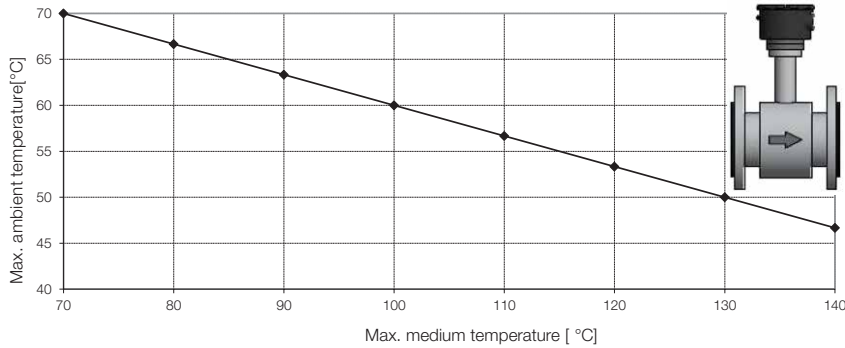

Remember to also consider the liner material max temperature limit.

Potential Equalization

The potential equalization is achieved via the grounding terminal of the junction box.

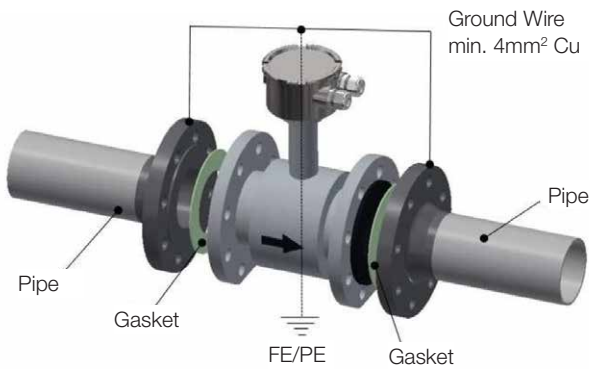

For metallic pipelines we recommend connecting the grounding terminal to the pipe.

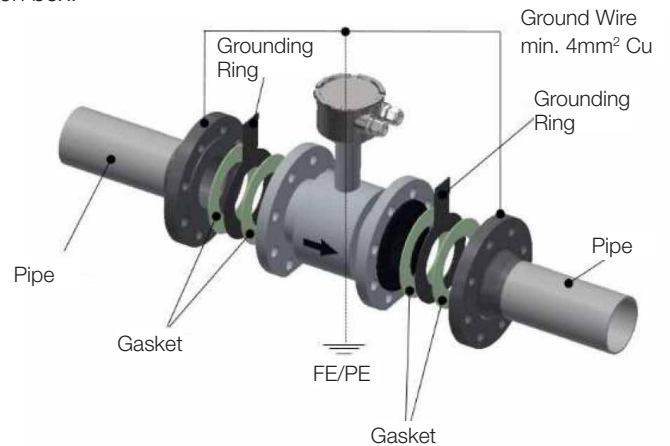

For non-metallic pipelines we recommend connecting the grounding terminal to the grounding rings.



Dimensions of the Transmitter UMF2

Transmitter Integral Mounted

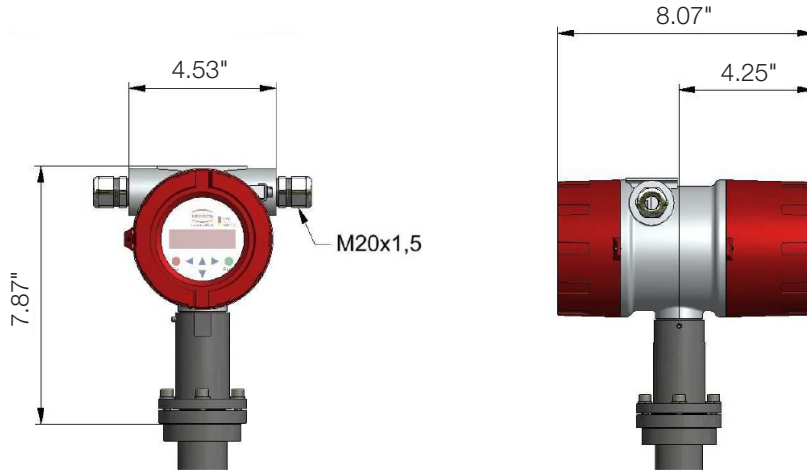

Transmitter for Remote Mounting

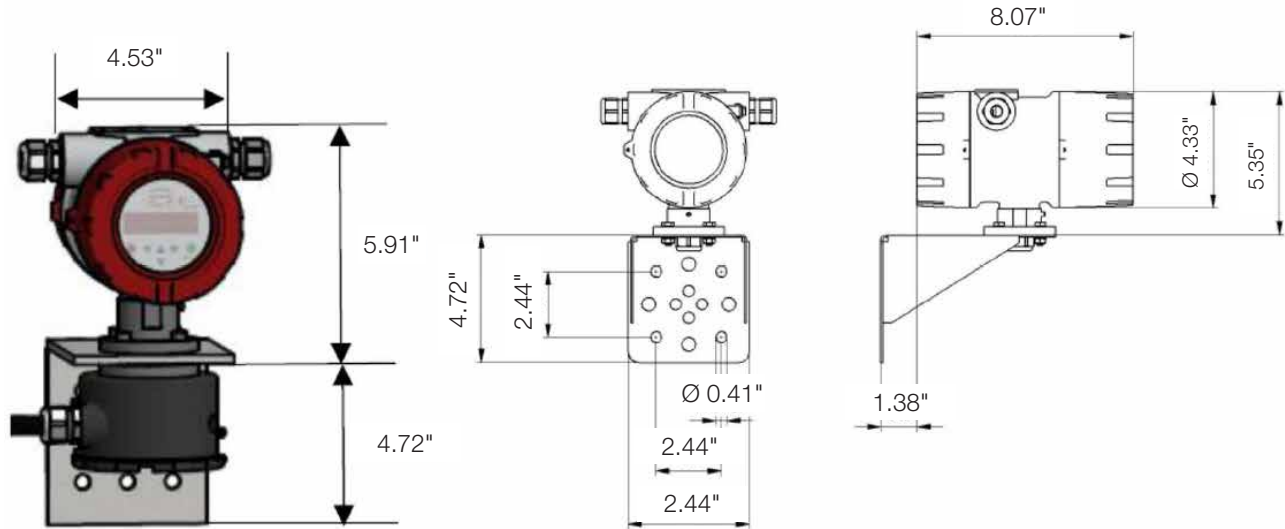

Junction Box (Sensor) for Remote Mounting

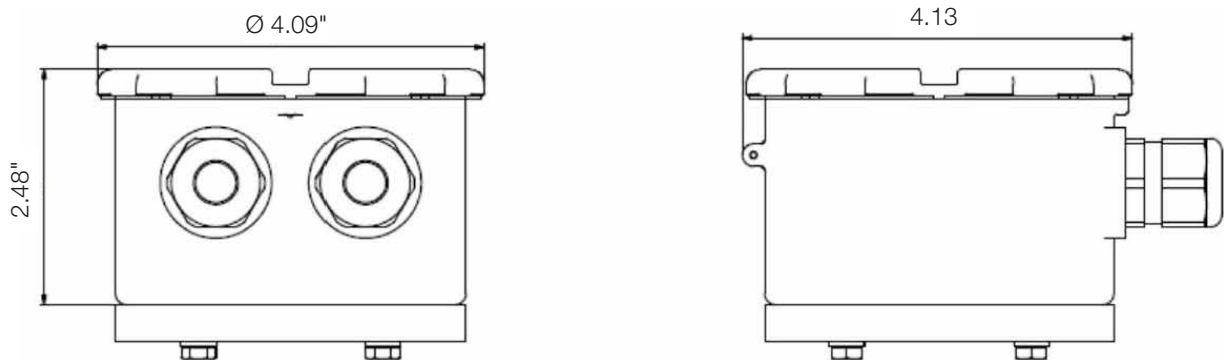

EPS Sensor Dimensions

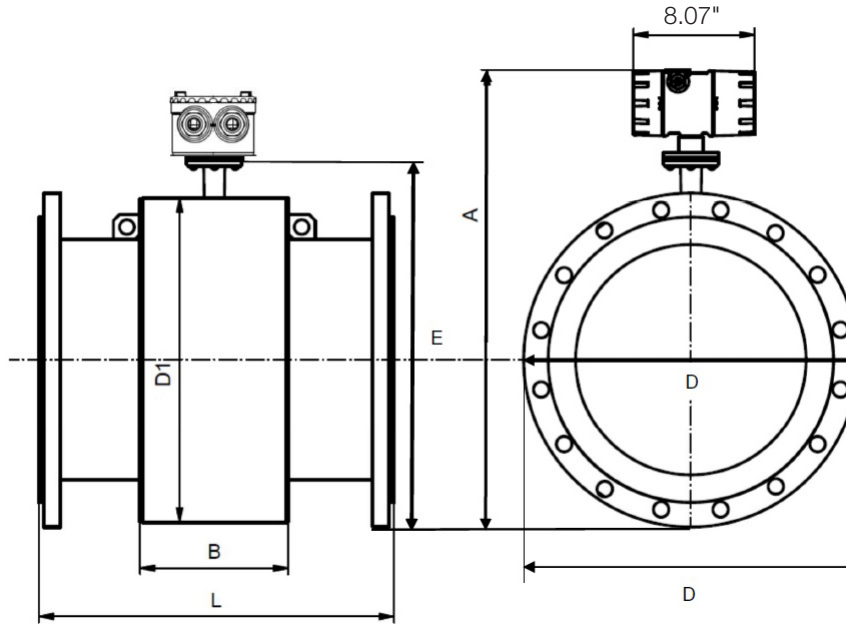

ANSI Connection	D		D1	E		A				B	L	Weight* lb
	ANSI			ANSI		ANSI with Transmitter		ANSI with Junction Box				
	150 lbs	300 lbs		150 lbs	300 lbs	150 lbs	300 lbs	150 lbs	300 lbs			
1/2"	3.50"	3.75"	4.10"	6.26"	6.26"	12.28"	12.28"	8.88"	8.88"	2.32"	7.9"	8.8
1"	4.25"	4.88"	4.10"	6.34"	6.65"	12.36"	12.68"	8.96"	9.27"	2.32"	7.9"	11.0
1 1/2"	5.00"	6.12"	4.88"	7.11"	7.67"	13.13"	13.69"	9.72"	10.28"	3.23"	7.9"	17.6
2"	6.00"	6.50"	5.47"	7.90"	8.15"	13.93"	14.18"	10.52"	10.77"	2.83"	7.9"	19.8
3"	7.50"	8.25"	6.85"	9.34"	9.72"	15.37"	15.74"	11.96"	12.33"	2.83"	7.9"	26.5
4"	9.00"	10.00"	8.43"	10.88"	11.38"	16.90"	17.40"	13.50"	14.00"	3.35"	9.8"	35.3
6"	11.00"	12.50"	11.10"	13.22"	13.97"	19.24"	19.99"	15.83"	16.59"	3.35"	11.8"	59.5
8"	13.50"	15.00"	13.31"	15.57"	16.32"	21.59"	22.34"	18.19"	18.94"	5.39"	13.8"	88.2
10"	16.00"	17.50"	15.47"	17.90"	18.65"	23.93"	24.68"	20.52"	21.27"	6.18"	17.7"	132.3
12"	19.00"	20.50"	17.48"	20.41"	21.16"	26.43"	27.18"	23.02"	23.78"	6.18"	19.7"	176.4
14"	21.00"	23.00"	17.76"	21.54"	22.54"	27.57"	28.57"	24.16"	25.16"	10.63"	21.7"	242.5
16"	23.50"	25.50"	19.76"	23.80"	24.80"	29.82"	30.82"	26.42"	27.42"	10.63"	23.6"	275.6
18"	25.00"	28.00"	22.17"	25.75"	27.25"	31.77"	33.27"	28.37"	29.87"	12.20"	23.6"	385.8
20"	27.48"	30.50"	24.17"	28.00"	29.50"	34.02"	35.53"	30.61"	32.12"	13.78"	23.6"	440.9
24"	32.00"	36.00"	28.15"	32.24"	34.24"	38.26"	40.26"	34.86"	36.86"	12.60"	23.6"	632.7

* Weights are approximate and are for 150 lb ANSI versions without a transmitter/display. Units with an integral transmitter/display carry an additional weight of 5.3 lbs.



Magnetic Inductive Flowmeter Model EPS

Dimensions

Ceramic Version with 1/2" NPT Connections

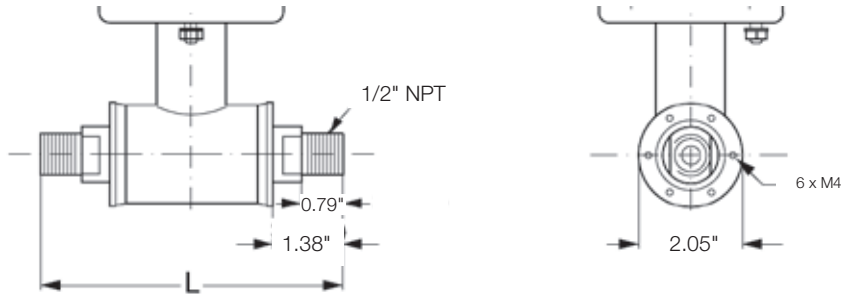

Size	Length Dimension L	
	EPDM	PTFE
1/12"	5.9"	6.1"
1/8"		
1/4"		
3/8"		

Dimensions

Tri-Clover® (BS4825-1) Version

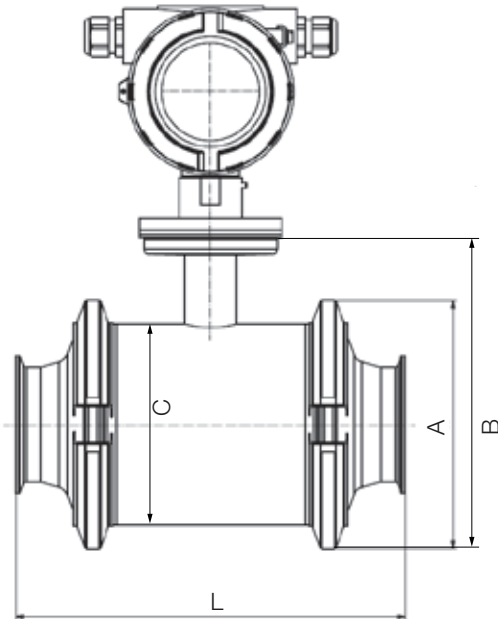

Size	A	B	C	L
1/2"	3.90"	6.26"	2.52"	5.75"
1"	4.45"	7.09"	3.05"	6.34"
1 1/2"	4.96"	8.15"	3.58"	6.93"
2"	6.06"	9.47"	4.68"	7.32"
3"	7.87"	11.69"	6.10"	10.16"
4"	8.86"	13.25"	7.20"	11.34"