



## Magnetic Filters and Dirt Traps



measuring  
•  
monitoring  
•  
analysing

### MFR/MFF/MFT

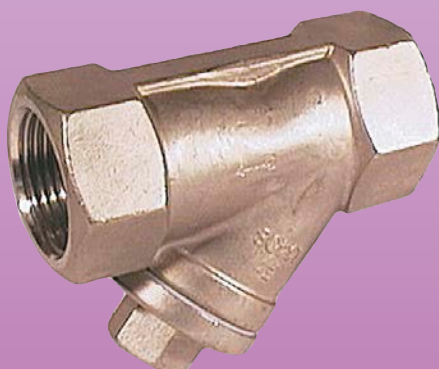
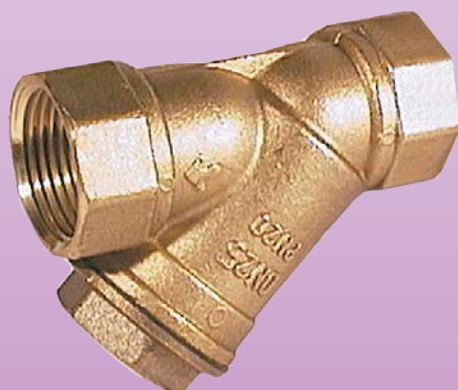

- $p_{\max}$ : PN 40
- $t_{\max}$ : +200 °C
- Screw thread: G 1/4 ... G 4
- Screw thread: Rp 1 ... Rp 2
- Flanges: DN 50 ... DN 200
- Solder connections:  
22 mm ... 35 mm
- Material: brass, stainless  
steel, bronze, cast iron
- Mesh sizes:  
50  $\mu\text{m}$  ... 1200  $\mu\text{m}$



12

KOBOLD companies worldwide:

AUSTRALIA, AUSTRIA, BELGIUM, BULGARIA, CANADA, CHINA, CZECHIA, FRANCE, GERMANY,  
GREAT BRITAIN, HUNGARY, INDIA, INDONESIA, ITALY, MALAYSIA, MEXICO, NETHERLANDS,  
PERU, POLAND, REPUBLIC OF KOREA, RUSSIA, SPAIN, SWITZERLAND, THAILAND, TUNISIA,  
TURKEY, USA, VIETNAM

KOBOLD Messring GmbH  
Nordring 22-24  
D-65719 Hofheim/Ts.  
Head Office:  
+49(0)6192 299-0  
+49(0)6192 23398  
info.de@kobold.com  
www.kobold.com

**Description**

KOBOLD magnetic filters are used in many applications, including central system filters, where it is necessary to protect devices from dirt and contamination. They are used to catch and remove contaminants from industrial cooling and lubrication circuits, especially where residue and sediment from assembly (such as chips from thread-cutting) and normal operation (such as scale and residue from frictional wear) can be carried along in the medium being filtered. Contaminants of these types can form deposits that can cause pitting and corrosion in highly sensitive measuring and control devices. Regular maintenance and cleaning of the magnetic filter inserts will effectively prevent system and device failure and the resulting downtime.

**Function**

The medium being filtered with these devices first flows around the centrally positioned bar magnet and then passes through – from the inside out – the stainless steel filter cartridge. The bar magnetic attracts and retains larger ferrous particles, thus making the magnetic filter easier to service. Larger, coarse pieces of material are trapped by the filter cartridge. The selected mesh sizes, from 150 to 1200  $\mu\text{m}$ , ensure that the filter does not get clogged with fine sludge and causes only a minor pressure loss.

**Magnetic filter, female thread, MFR-00**

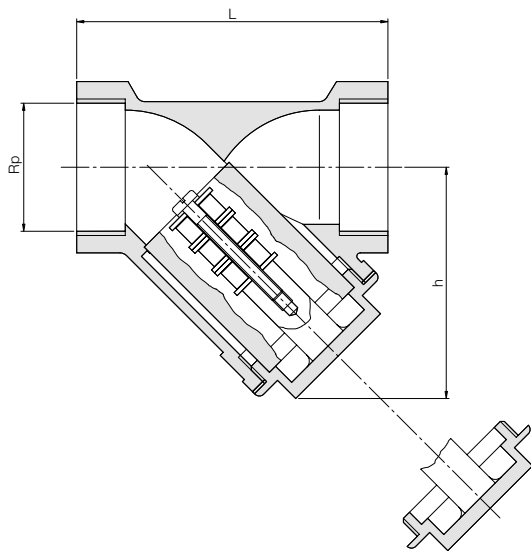

**Adapter magnetic filter, female thread, MFT-I**

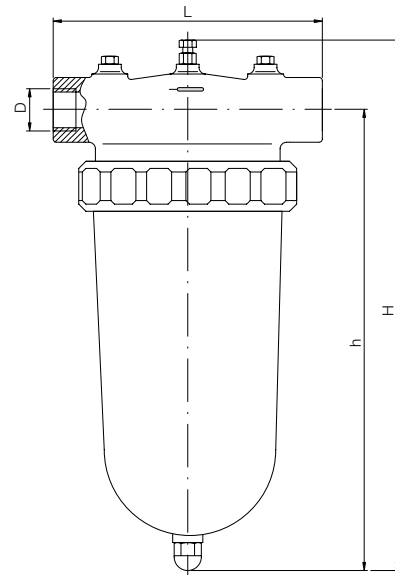

**Flange magnetic filter, MFF-**

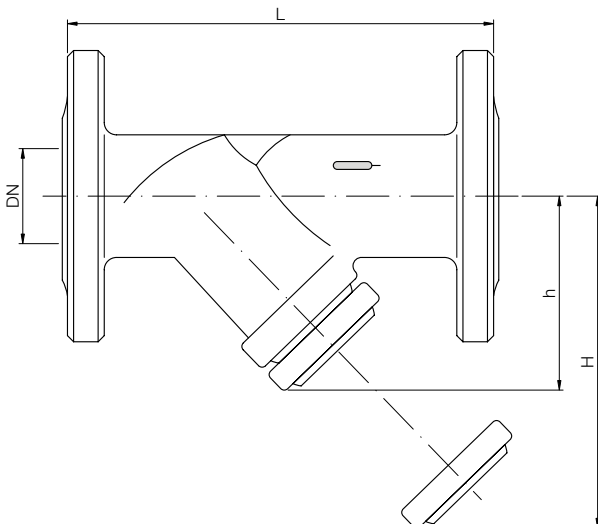

**Adapter magnetic filter, threaded connection, MFT-A, MFT-L**

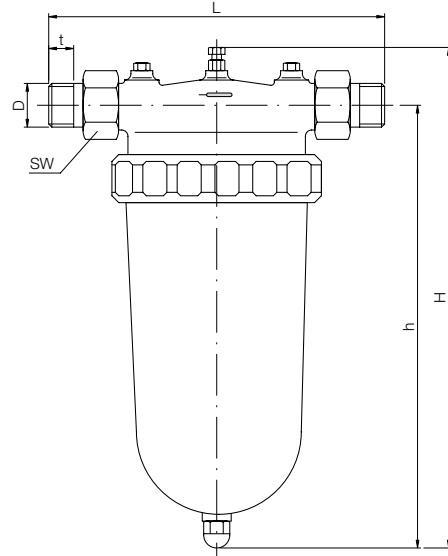



**Materials**

Screw-on magnetic filter: body bronze  
 Adapter magnetic filter: body brass  
 Flange magnetic filter: body cast iron, coated  
 Filter cartridge: stainless steel  
 Magnets: oxide ceramic  
 Gasket: Klinger Sil® C-4300

**Mounting**

Screw-on magnetic filter: horizontal or vertical  
 Adapter magnetic filter: horizontal  
 Flange magnetic filter: horizontal or vertical

**Maintenance**

First check after being put into operation. Thereafter, frequency of checks are dependent on actual rate of contamination, with at least one check per year.

**Cleaning**

Clean with water stream/compressed air and brush.

**Technical Details**

Thread connection: female thread G ½ ... G3  
 male thread R ¾ ... R 1 ¼  
 (according to DIN 2999)  
 Solder connections: 22 mm ... 35 mm  
 Flanges: according to DIN 2533  
 DN 50 ... DN 200

**Nominal pressures**

Screw-on magnetic filter: PN 16  
 Adapter magnetic filter: PN 10  
 Flange magnetic filter: PN 16

**Max. temperature**

Screw-on magnetic filter: 200 °C  
 Adapter magnetic filter: 90 °C  
 Flange magnetic filter: 200 °C  
 Mesh size: see table

**Dimensions and Order Details** (example: **MFR-0015**)

Version	Conne- ction	k <sub>v</sub> -value [m³/h]	Mesh size [µm]	Size of filter cartridge [mm]	L [mm]	h [mm]	H [mm]	t [mm]	AF [mm]	Weight [kg]	ID no.
Female thread	G ½	6.2	280	19/32	64	45	-	-	-	0.3	MFR-0015
	G ¾	7.7	280	25/38	74	55	-	-	-	0.3	MFR-0020
	G 1	12.4	280	29/46	82	62	-	-	-	0.4	MFR-0025
	G 1¼	13.9	280	37/55	96	73	-	-	-	0.5	MFR-0032
	G 1½	18.5	280	43/61	112	84	-	-	-	0.9	MFR-0040
	G 2	31	280	58/75	134	103	-	-	-	2.2	MFR-0050
	G 2½	56	280	66/9	151	105	-	-	-	2.8	MFR-0065
	G 3	80	530	80/130	172	129	-	-	-	4.8	MFR-0080
Female thread adapter	Rp 1	17.5	600	70/197	130	283	324	-	-	5.1	MFT-I025
	Rp 1¼	20	600	70/197	135	283	324	-	-	5.1	MFT-I032
	Rp 1½	25	600	70/197	150	293	338	-	-	5.5	MFT-I040
	Rp 2	33	600	70/197	160	299	351	-	-	6.0	MFT-I050
Male thread adapter	R ¾	12	600	70/197	192	283	324	11	37	5.3	MFT-A020
	R 1	17.5	600	70/197	223	283	324	19	46	5.5	MFT-A025
	R 1¼	21	600	70/197	253	283	324	21.5	52	5.9	MFT-A032
Solder connection adapter	22 mm	12	600	70/197	176	283	324	17	37	5.3	MFT-L020
	28 mm	17.5	600	70/197	184	283	324	18.5	46	5.5	MFT-L025
	35 mm	21	600	70/197	200	283	324	23.5	52	5.9	MFT-L032
Flange	DN 50	47	750	58/105	230	120	190	-	-	9.0	MFF-0050
	DN 65	75	750	73/123	290	140	220	-	-	13.0	MFF-0065
	DN 80	113	1200	88/144	310	165	265	-	-	17.0	MFF-0080
	DN 100	189	1200	108/184	350	220	340	-	-	27.0	MFF-0100
	DN 125	303	1200	135/221	400	260	410	-	-	41.0	MFF-0125
	DN 150	379	1200	160/260	480	300	475	-	-	62.0	MFF-0150
	DN 200	758	1200	208/360	600	360	580	-	-	115.0	MFF-0200

**Technical Details MFR-female thread (brass version)**

Design: two-part screwed body  
 Connections: female thread G ¼ ... G 4  
 DIN ISO 228  
 Nominal pressure: see table  
 Temperature range: max. 90°C (water)  
 -15°C ... 110°C (air)  
 Mesh size: see table  
 Mounting position: cover toward bottom,  
 note specified direction of flow

**Materials**

Body: brass Ms 58  
 Cover: brass Ms 58  
 Mesh: stainless steel AISI304  
 Cap seal: NBR  
 G 2½ ... G 4 = Betaflex 71  
 cellulose with NBR

**MFR-IG**

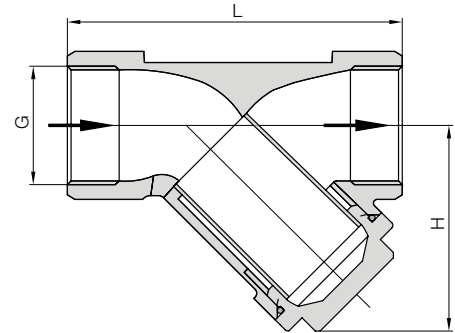

**Dimensions and Order Details**

**MFR-IG brass version**  
 (example: MFR-IGR15)

Screw thread [G]	k <sub>v</sub> -value [m³/h]	Order no.	Mesh size [µm]	L [mm]	H [mm]	Nominal pressure	Weight [kg]
¼	2.20	MFR-IGR 08	500	55	40	PN20	0.13
¼		MFR-IGR 08 (F)	50	55	40		
¾	3.43	MFR-IGR 10	500	55	40		0.13
¾		MFR-IGR 10 (F)	50	55	40		
½	4.48	MFR-IGR 15	500	58	40		0.15
½		MFR-IGR 15 (F)	50	58	40		
¾	7.86	MFR-IGR 20	500	70	48		0.24
¾		MFR-IGR 20 (F)	50	70	48		
1	11	MFR-IGR 25	500	87	56		0.38
1		MFR-IGR 25 (F)	50	87	56		
1¼	16	MFR-IGR 32	500	96	64		0.56
1¼		MFR-IGR 32 (F)	50	96	64		
1½	22	MFR-IGR 40	500	106	73		0.7
1½		MFR-IGR 40 (F)	50	106	73		
2	35	MFR-IGR 50	500	126	89	1.2	
2		MFR-IGR 50 (F)	50	126	89		
2½	60	MFR-IGR 65	800	150	107	PN16	2.2
3	83	MFR-IGR 80	800	169	120		3.1
4	100	MFR-IGR 1H	800	219	161		6.6

**Technical Details MFR-EA (version stainless steel)**

Design:	two-part screwed body
Connections:	female thread G ½... G 2 DIN ISO 228 T1
Nominal pressure:	PN 40
Temperature range:	-30 °C ... +180 °C (air)
Mesh size:	filter (standard) 500 µm filter (fine) 250 µm
Mounting position:	cover toward bottom, note specified direction of flow

**Materials**

Body:	stainless steel 1.4408
Cover:	stainless steel 1.4408
Mesh:	stainless steel 1.4301
Gasket:	PTFE

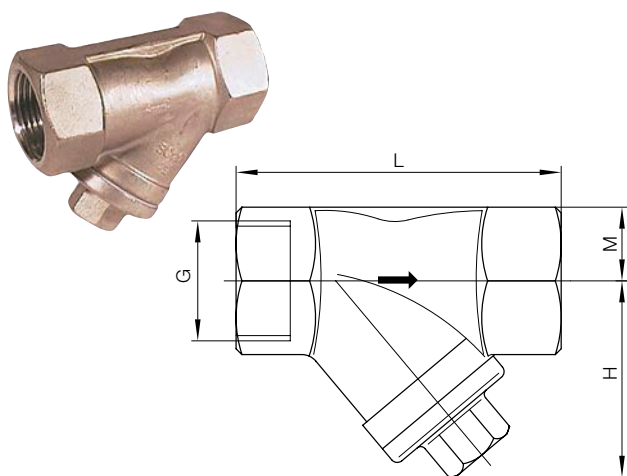
**MFR-EA****Dimensions and Order Details****MFR-EA stainless steel version**

(example: MFR-EAR15E)

Screw thread [G]	Order no. filter (standard)	Order no. filter (fine)	M [mm]	H [mm]	L [mm]
½	MFR-EAR15E	MFR-EAR15D	12.5	42.5	65.0
¾	MFR-EAR20E	MFR-EAR20D	15.5	49.0	75.0
1	MFR-EAR25E	MFR-EAR25D	18.5	57.5	90.0
1¼	MFR-EAR32E	MFR-EAR32D	23.0	65.0	110.0
1½	MFR-EAR40E	MFR-EAR40D	26.5	74.0	120.0
2	MFR-EAR50E	MFR-EAR50D	33.5	85.0	150.0

**Technical Details MFR-DO (version stainless steel)**

Design: two-part screwed body  
 Connections: female thread G ¼ ... G 3  
 DIN ISO 228-1  
 Nominal pressure: PN 40  
 Temperature range: -20 °C ... +180 °C  
 Mesh size: 200 mesh/75 µm for G ¼, G ¾  
 100 mesh/150 µm for G ½, G 1, G 1½  
 40 mesh/400 µm for G 2, G 3  
 Mounting position: cover toward bottom,  
 note specified direction of flow

**Materials**

Body (1): stainless steel 1.4408, EN1503-1  
 Plug (2): stainless steel 1.4408, EN1503-1  
 Screen (4): stainless steel 316  
 Bonnet (9): stainless steel 1.4408, EN1503-1  
 Body seal (11): PTFE  
 O-ring (31): FPM

**MFR-DO**

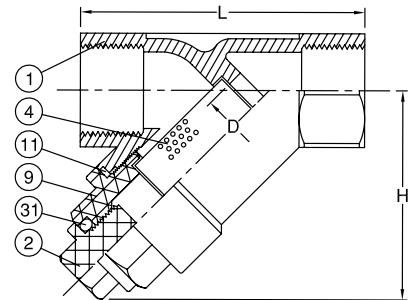

**Dimensions, weight and Order Details**

**MFR-DO stainless steel version**  
 (example: MFR-DOR15)

Order no.	Size		L [mm]	H [mm]	D [mm]	Weight [kg]
	DN	inch				
MFR-DOR08	DN08	¼"	65.0	51.0	10.0	0.25
MFR-DOR10	DN10	⅜"	65.0	51.0	12.0	0.25
MFR-DOR15	DN15	½"	65.0	51.0	15.0	0.25
MFR-DOR25	DN25	1"	90.0	72.0	25.0	0.70
MFR-DOR40	DN40	1½"	120.0	87.0	40.0	1.20
MFR-DOR50	DN50	2"	140.0	103.0	50.0	1.90
MFR-DOR80	DN80	3"	200.0	143.0	80.0	6.16