



Insertion Resistance Thermometers

with, or without transmitter



measuring
•
monitoring
•
analysing

MMA

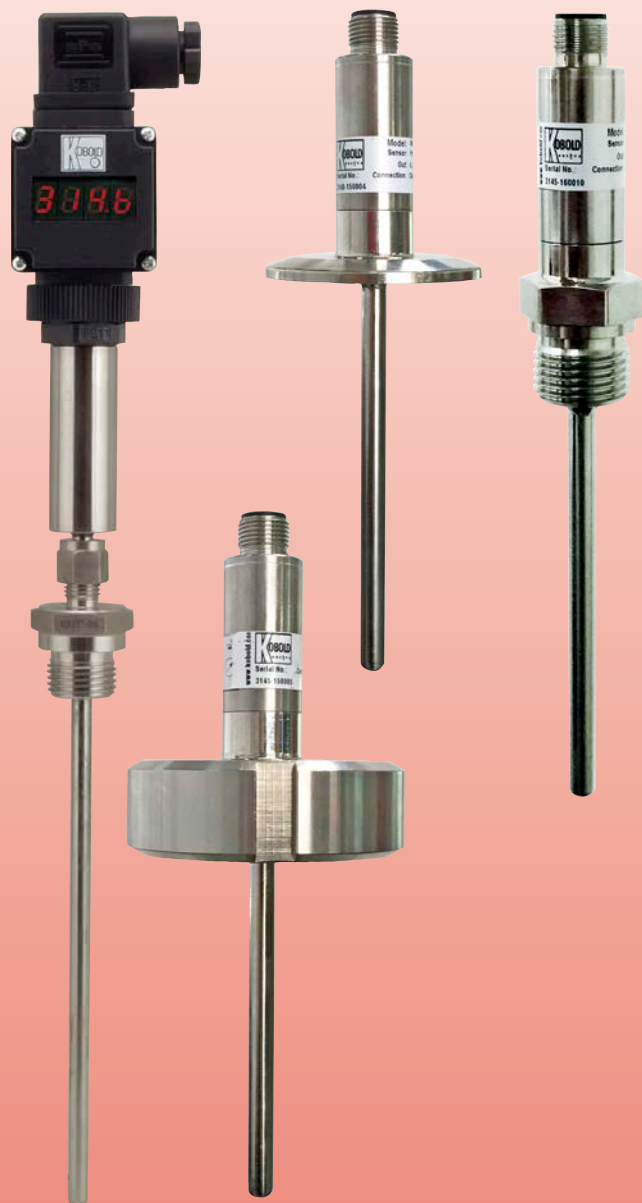

- Economically-priced digital thermometers with optional plug-on display
- Compact construction with or without transmitter 4-20 mA output: PC-configurable range by software
- Measuring ranges:
-198 ... +250 °C
others on request
- Pt100 sensor class F0.15 (A), F0.1 (1/3 DIN), F0.03 (1/10 DIN) or cryogenic
- Process connection threaded, clamp DIN 32676, VARIVENT®, or union nut DIN 11851
- Electrical connection DIN 43650, or M12
- Material stainless steel
- Good immunity to vibration

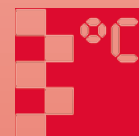

T2

KOBOLD companies worldwide:

AUSTRALIA, AUSTRIA, BELGIUM, BULGARIA, CANADA, CHINA, CZECHIA, FRANCE, GERMANY, GREAT BRITAIN, HUNGARY, INDIA, INDONESIA, ITALY, MALAYSIA, MEXICO, NETHERLANDS, PERU, POLAND, REPUBLIC OF KOREA, SPAIN, SWITZERLAND, THAILAND, TUNISIA, TURKEY, USA, VIETNAM

KOBOLD Messring GmbH
Nordring 22-24
D-65719 Hofheim/Ts.
Head Office:
+49(0)6192 299-0
+49(0)6192 23398
info.de@kobold.com
www.kobold.com



Description

The screw-in temperature sensors with integrated transmitter can be used with the plug-on display model AUF.. as economical digital thermometers with analogue output (4-20 mA). The plug-on display is available with limit contact as an option.

The model MMA-... temperature probe connections are made of stainless steel available in G $\frac{1}{4}$, G $\frac{1}{2}$, $\frac{1}{2}$ " NPT, clamp DIN32676, VARIVENT® or Union Nut DIN11851. The bulbs have been designed for pressures up to 36 bar, depending on the process conditions.

Due to a DIN43650 connector the transmitter can be cable-connected or retrofitted with the plug-on display very easily. The M12 connector has the same cable-connection properties.

The temperature sensor is equipped with an extension neck for process temperatures >150 °C.

The Pt100 temperature sensor is conform to IEC60751, class F0.15 (A), F0.1 ($\frac{1}{3}$ DIN), F0.03 ($\frac{1}{10}$ DIN) or cryogenic (for further information see order details).

Integrated Transmitter

Temperature sensors with transmitter are capable of transmitting measuring signals noise-free over long distances.

The two-wire transmitter is integrated in the resistance thermometer. The output-signal is 4-20 mA. The transmitter is configurable from PC through the Loop Link communication interface and PReset software. A cable with M12 connector is needed. .

Applications

- Heating installation, furnace and apparatus construction
- Machine construction and building installations
- Marine engineering
- General industrial
- Food
- Pharmaceutical industry

Technical Details

Temperature probe

Bulb: stainless steel 1.4404
 Thread: stainless steel 1.4404
 G $\frac{1}{4}$, G $\frac{1}{2}$, $\frac{1}{2}$ " NPT
 clamp DIN32676
 VARIVENT®
 union nut DIN11851

Transmitter housing: stainless steel
 P_{max} : 36 bar
 Sensor element: Pt100 sensor class F0.15 (A), F0.1 ($\frac{1}{3}$ DIN), F0.03 ($\frac{1}{10}$ DIN) or cryogenic

Connector: DIN43650 or M12
 Protection: IP 65 connector DIN 43650 / M12 connector IP67

Measuring range: -198 ... +250 °C (MMA-H)
 -70 ... +150 °C (MMA-0)

Max. temperature: 400°C on request
 Accuracy: <0.5% of measuring span

Transmitter

Output: 4-20 mA 2-wire
 Supply: 8 ... 35 V_{DC}
 Min. measuring range: 25 °C
 Ambient temperature: -40 ... +85 °C

Plug-on display optional (not included in delivery)

Display: 4-digit, red LED
 height of digits 7.62 mm

Indicating range: -1999 ... +9999

Voltage drop: $\leq 5 V_{DC}$

Programming: via 2 buttons, menu-assisted
 scaling of indicating range decimal
 point, damping, fault indication,
 switch point (optional)

Protection: IP 65
 Ambient temperature: 0 ... +60 °C

Order Details Plug-on display

Model	Description
AUF-1000	Standard plug-on display, 4 -20 mA, 2-wire
AUF-1001	Plug-on display with Open Collector, 4 -20 mA, 2-wire

Order Details Process Connection Slidable Compression Fitting (Example: MMA-0 03 K15 C 2 D 0 0)

Model	Insertion length »EL«/ probe Ø [mm]	Process connection	Sensor type/ category	RTD wiring	Electrical connection	Head connection	Options
MMA-0	03 = 25 mm/Ø6	000 = without K15 = compression fitting G ½-M L15 = compression fitting ½" NPT XXX = special options	C = 1xPt100 class F0.15 (A) (-70 ... +150°C) M = 1xPt100 class F0.1 (½ DIN) (-70 ... +150°C) N = 1xPt100 class F0.03 (⅓ DIN) (-70 ... +150°C) Q = 1xPt100 class B cryogenic type (-198 ... +100°C) X = special options	2 = 2-wire 3 = 3-wire 4 = 4-wire	D = DIN 43650 M = M12	0 = without transmitter A* = with 4-20 mA transmitter standard configuration 0...100°C B* = with 4-20 mA transmitter special configuration	0 = without Y = according to specifications
	05 = 50 mm/Ø6						
	10 = 100 mm/Ø6						
	16 = 160 mm/Ø6						
	20 = 200 mm/Ø6						
	25 = 250 mm/Ø6						
	30 = 300 mm/Ø6						
	40 = 400 mm/Ø6						
	50 = 500 mm/Ø6						
	60 = 600 mm/Ø6						
XX = special length/probe Ø							

* Only with RTD wiring option 3

Dimensions [mm]

Model MMA-0 process connection slidable compression fitting

with plug and socket connection according to DIN 43650 or M12 connection

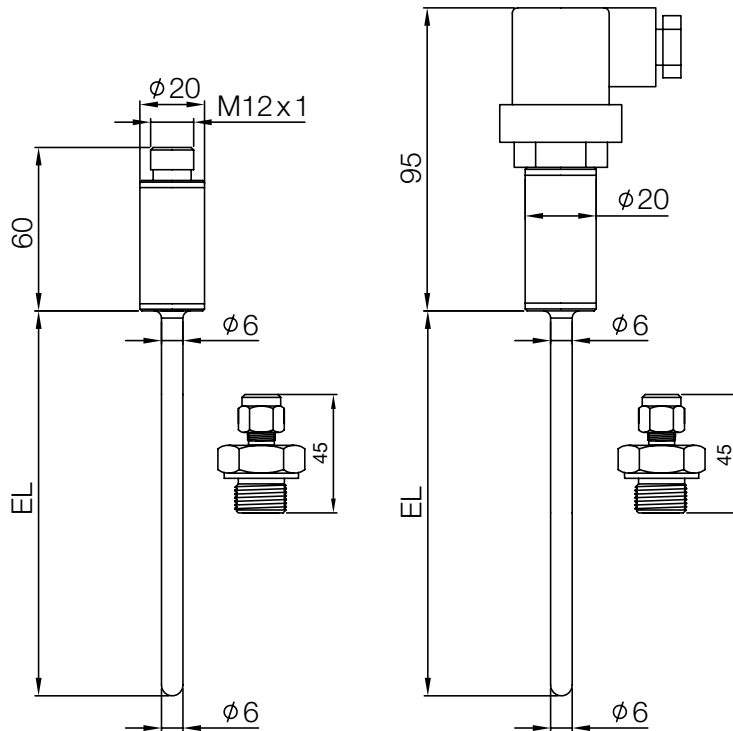

Order Details Process Connection Fixed Thread (Example: MMA-0 03 G15 C 2 D 0 0)

Model	Insertion length »EL«/ probe Ø [mm]	Process connection	Sensor type/category	RTD wiring	Electrical connection	Head transmitter	Options
MMA-0 ¹⁾	03 = 25 mm/Ø6	G08 = G ¼-M G15 = G ½-M N08 = ¼" NPT-M N15 = ½" NPT-M XXX = special options	C = 1xPt100 class F0.15 (A) (-70...+150°C)	2 = 2-wire 3 = 3-wire 4 = 4-wire	D = DIN 43650 M = M12	0 = without transmitter A ²⁾ = with 4-20 mA transmitter standard configuration 0...100°C B ²⁾ = with 4-20 mA transmitter special configuration	0 = without Y = according to specifications
	05 = 50 mm/Ø6		M = 1xPt100 class F0.1 (½ DIN) (-70...+150°C)				
	10 = 100 mm/Ø6		N = 1xPt100 class F0.03 (⅓ DIN) (-70...+150°C)				
	16 = 160 mm/Ø6		Q = 1xPt100 class B cryogenic type (-198...+100°C)				
	20 = 200 mm/Ø6		X = special options				
MMA-H	25 = 250 mm/Ø6						
	30 = 300 mm/Ø6						
	40 = 400 mm/Ø6						
	50 = 500 mm/Ø6						
	60 = 600 mm/Ø6						
	XX = special length/ probe Ø						

¹⁾ Maximum range -40...150°C with transmitter ²⁾ Only with RTD wiring option 3

Dimensions [mm]

Model MMA-0 process connection fixed thread

with plug and socket connection according to DIN 43650 or M12 connection.

Without extension length 150°C max.

For NPT thread

LN = screw-in-length by hand

6 mm at ¼" NPT

8.1 mm at ½" NPT

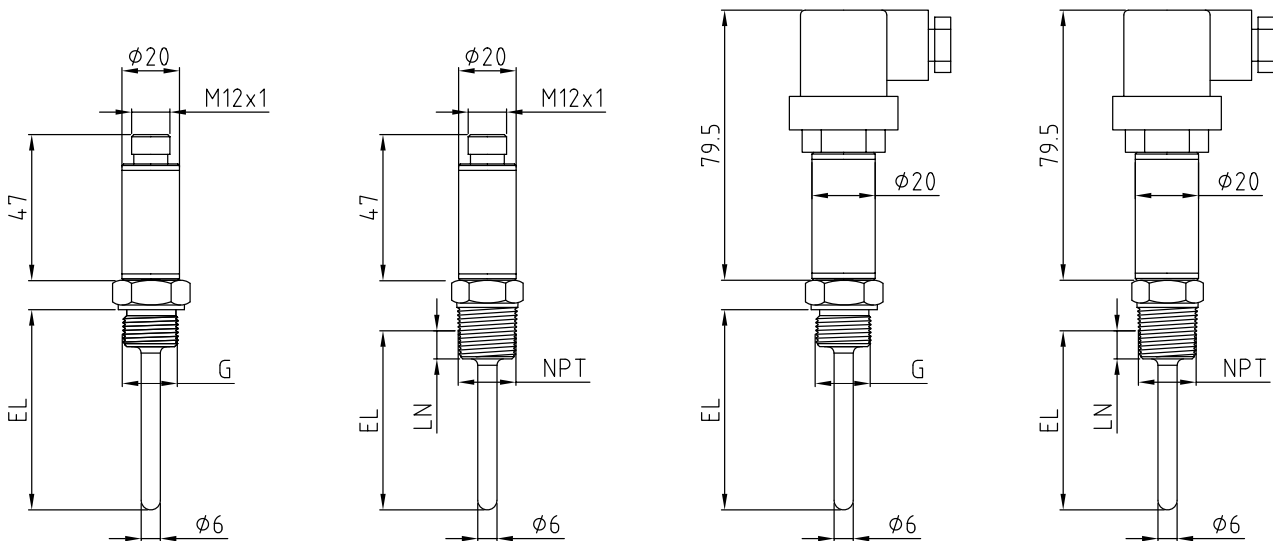

Model MMA-H process connection fixed thread

with plug and socket connection according to DIN 43650 or M12 connection.

Extension length 50 mm (Range up to 250 °C)

For NPT thread

LN = screw-in-length by hand

6 mm at 1/4" NPT

8.1 mm at 1/2" NPT

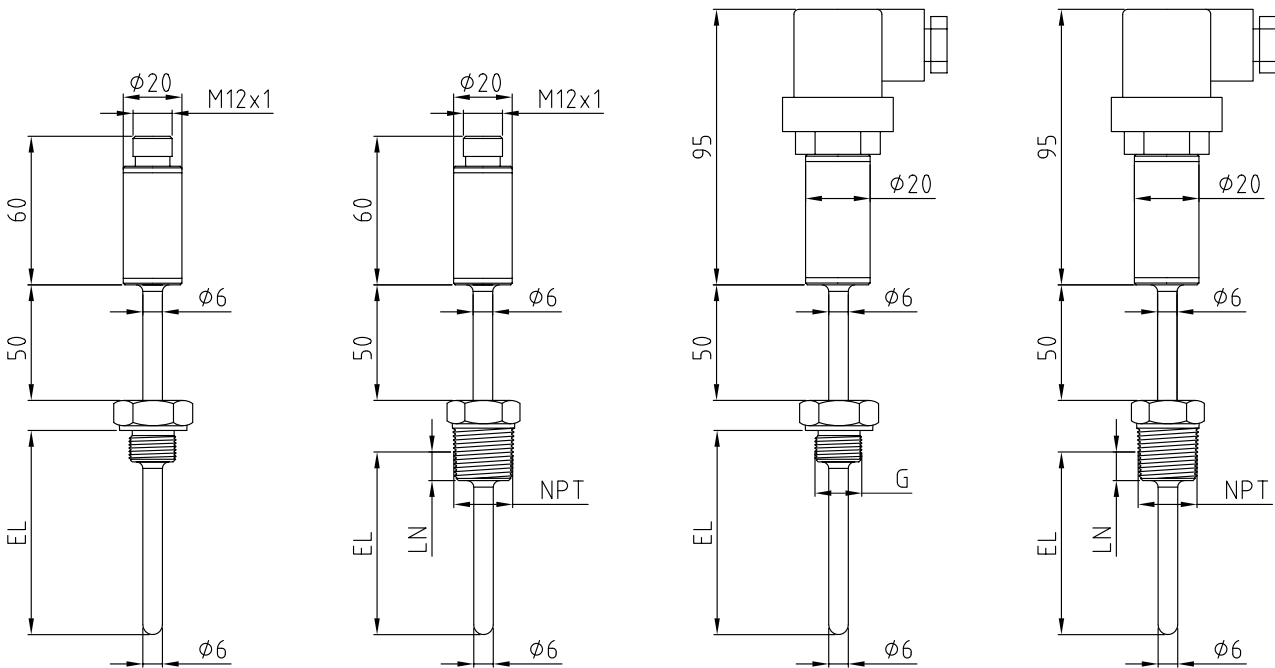

Order Details Process Connection DIN 32676 (Example: MMA-0 03 C15 C 2 D 0 0)

Model	Insertion length »EL«/ probe Ø [mm]	Process connection	Sensor type/ category	RTD wiring	Electrical connection	Head transmitter	Options	
MMA-0 ¹⁾	03 = 25 mm/Ø6 05 = 50 mm/Ø6 10 = 100 mm/Ø6 16 = 160 mm/Ø6 20 = 200 mm/Ø6 25 = 250 mm/Ø6 30 = 300 mm/Ø6 40 = 400 mm/Ø6 50 = 500 mm/Ø6 60 = 600 mm/Ø6 XX = special length/probe Ø	C10 = Tri-Clamp® DN10 Ø34) C15 = Tri-Clamp® DN15 Ø34) C20 = Tri-Clamp® DN20 Ø34) C25 = Tri-Clamp® DN25 Ø50.5) C40 = Tri-Clamp® DN40 Ø50.5) C50 = Tri-Clamp® DN50 Ø64) D15 = Tri-Clamp® ½" Ø25) D20 = Tri-Clamp® ¾" Ø25) D25 = Tri-Clamp® 1" Ø50.5) D32 = Tri-Clamp® 1½" Ø50.5) D50 = Tri-Clamp® 2" Ø64) XXX = special options	C = 1xPt100 class F0.15 (A) (-70... +150°C) M = 1xPt100 class F0.1 (⅓ DIN) (-70... +150°C) N = 1xPt100 class F0.03 (⅒ DIN) (-70... +150°C) Q = 1xPt100 class B cryogenic type (-198... +100°C) X = special options	2 = 2-wire 3 = 3-wire 4 = 4-wire	D = DIN 43650 M = M12	0 = without transmitter A²⁾ = with 4-20 mA transmitter standard configuration 0...100°C B²⁾ = with 4-20 mA transmitter special configuration	0 = without Y = accord- ing to specifi- cations	
								MMA-H

¹⁾ Maximum range -40...150°C with transmitter ²⁾ Only with RTD wiring option 3

Dimensions [mm]

Model MMA-0 process connection acc. to DIN 32676
 with plug and socket connection according to DIN 43650 or
 M12 connection

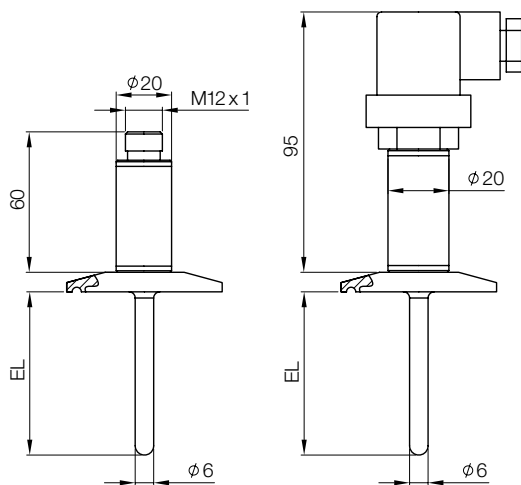

Model MMA-H process connection acc. to DIN 32676
 with plug and socket connection according to DIN 43650 or
 M12 connection.
 Extension length 50 mm (Range up to 250°C)

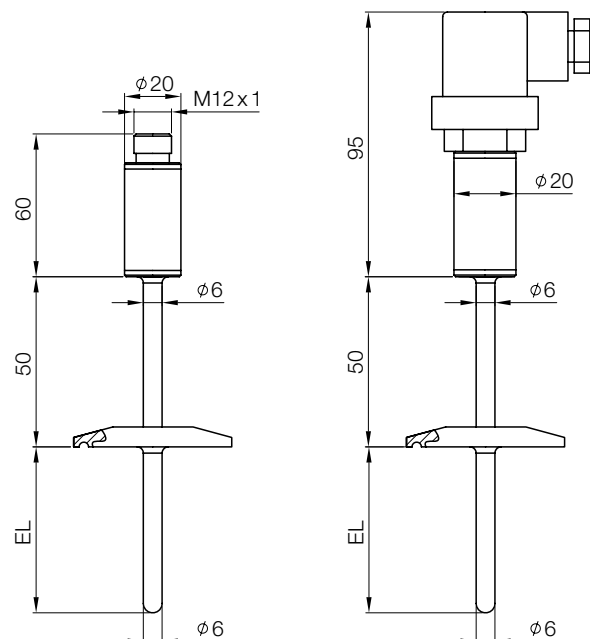

Order Details VARIVENT® connection (Example: MMA-0 03 V10 C 2 D 0 0)

Model	Insertion length »EL«/ probe Ø [mm]	Process connection	Sensor type/ category	RTD wiring	Electrical connection	Head transmitter	Options
MMA-0 ¹⁾	03 = 25 mm/Ø6	V10 = VARIVENT® DN10 V15 = VARIVENT® DN15 V25 = VARIVENT® DN25 V32 = VARIVENT® DN32 V40 = VARIVENT® DN40 V50 = VARIVENT® DN50	C = 1xPt100 class F0.15 (A) (-70...+150°C) M = 1xPt100 class F0.1 (1/10 DIN) (-70...+150°C) N = 1xPt100 class F0.03 (1/100 DIN) (-70...+150°C) Q = 1xPt100 class B cryogenic type (-198...+100°C) X = special options	2 = 2-wire 3 = 3-wire 4 = 4-wire	D = DIN 43650 M = M12	0 = without transmitter A ²⁾ = with 4-20 mA transmitter standard configuration 0...100°C B ²⁾ = with 4-20 mA transmitter special configuration	0 = without according to specifica- tions Y = accord- ing to specifica- tions
	05 = 50 mm/Ø6						
	10 = 100 mm/Ø6						
	16 = 160 mm/Ø6						
	20 = 200 mm/Ø6						
MMA-H	25 = 250 mm/Ø6						
	30 = 300 mm/Ø6						
	40 = 400 mm/Ø6						
	50 = 500 mm/Ø6						
	60 = 600 mm/Ø6						
	XX = special length/ probe Ø						

¹⁾ Maximum range -40...150°C with transmitter ²⁾ Only with RTD wiring option 3

Dimensions [mm]

Model MMA-0 process connection VARIVENT®

with plug and socket connection according to DIN 43650 or M12 connection

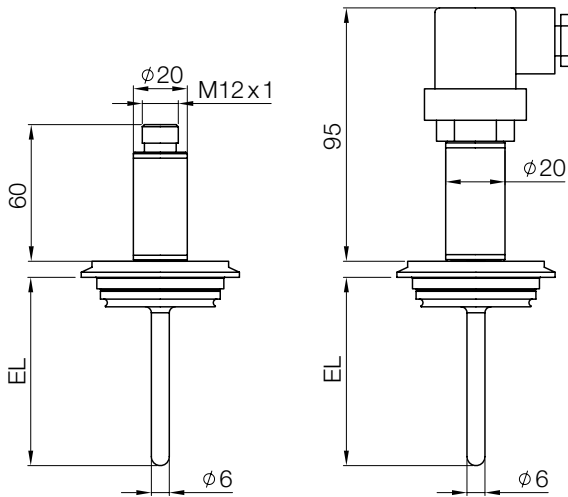

Model MMA-H process connection VARIVENT®

with plug and socket connection according to DIN 43650 or M12 connection.

Extension length 50 mm (Range up to 250 °C)

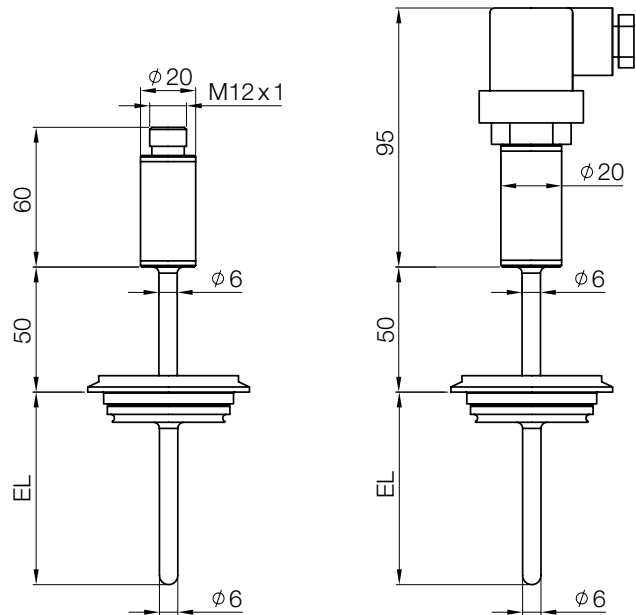

Order Details Process Connection acc. to DIN 11851 (Example: MMA-0 03 U20 C 2 D 0 0)

Model	Insertion length »EL«/ probe Ø [mm]	Process connection	Sensor type/ category	RTD wiring	Electrical connection	Head transmitter	Options		
MMA-0 ¹⁾	03 = 25 mm/Ø6	U20 = union nut DIN 11851 DN20	C = 1xPt100 class F0.15 (A) (-70...+150°C)	2 = 2-wire 3 = 3-wire 4 = 4-wire	D = DIN 43650 M = M12	0 = without transmitter A ²⁾ = with 4-20 mA transmitter standard configuration 0...100°C B ²⁾ = with 4-20 mA transmitter special configuration	0 = without Y = according to speci- fications		
	05 = 50 mm/Ø6							U25 = union nut DIN 11851 DN25	M = 1xPt100 class F0.1 (½ DIN) (-70...+150°C)
	10 = 100 mm/Ø6								
	16 = 160 mm/Ø6	U32 = union nut DIN 11851 DN32	N = 1xPt100 class F0.03 (⅓ DIN) (-70...+150°C)						
	20 = 200 mm/Ø6							U40 = union nut DIN 11851 DN40	Q = 1xPt100 class B cryogenic type (-198...+100°C)
	25 = 250 mm/Ø6								
MMA-H	30 = 300 mm/Ø6	U50 = union nut DIN 11851 DN50	X = special options						
	40 = 400 mm/Ø6								
	50 = 500 mm/Ø6								
	60 = 600 mm/Ø6								
	XX = special length/ probe Ø								

¹⁾ Maximum range -40...150°C with transmitter ²⁾ Only with RTD wiring option 3

Dimensions [mm]

Model MMA-0 process connection acc. to DIN 11851

with plug and socket connection according to DIN 43650 or M12 connection

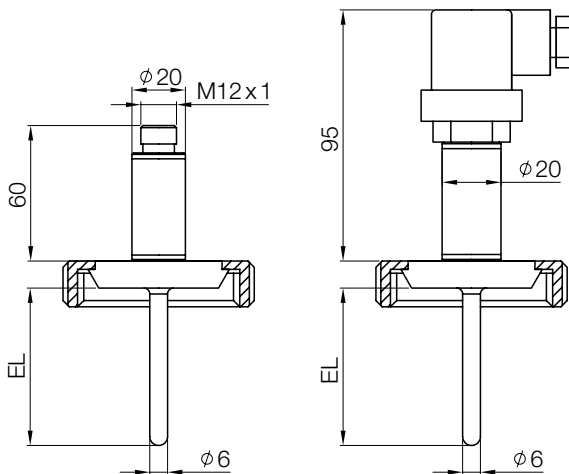

Model MMA-H process connection acc. to DIN 11851

with plug and socket connection according to DIN 43650 or M12 connection.

Extension length 50 mm (Range up to 250 °C)

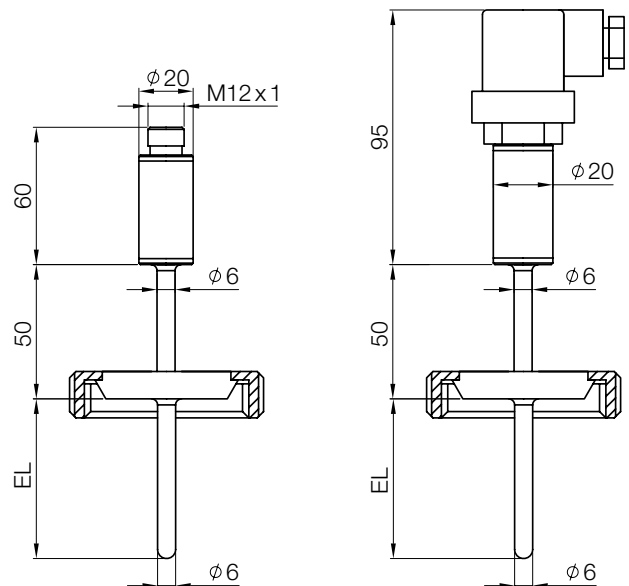



Accessories

Configuration software and hardware on request!

Dimensions Process Connection [mm]

Thread

LN = screw-in-length by hand
 6 mm at 1/4" NPT
 8.1 mm at 1/2" NPT

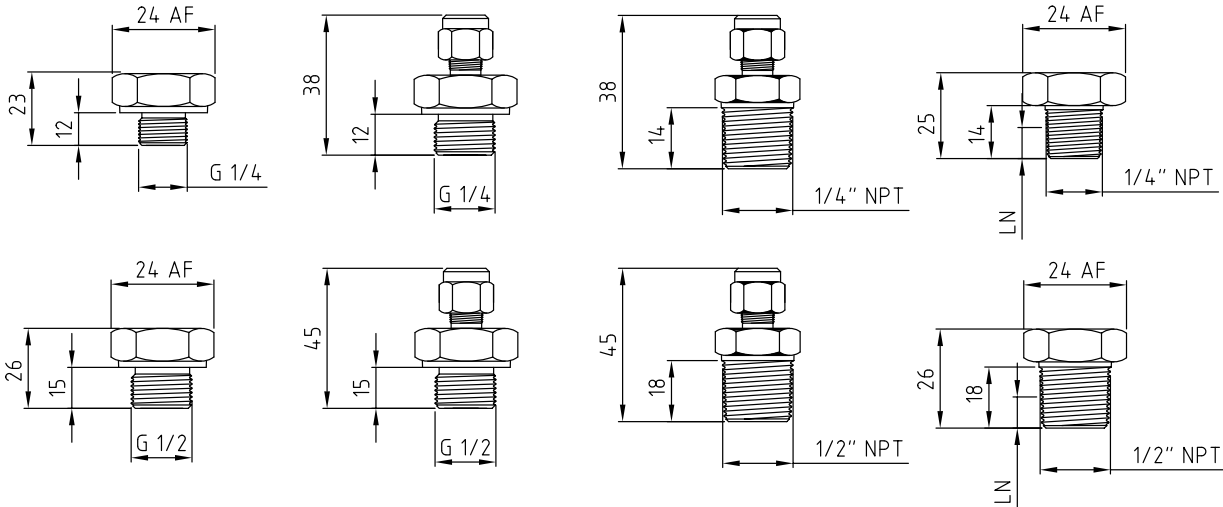

Clamp DIN 32676

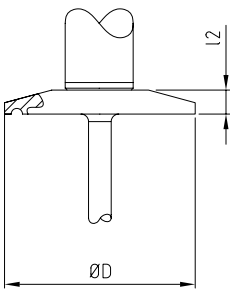

Connection	Nominal width	PN	ØD [mm]	l2 [mm]
C10 C15 C20	DN10...20	16	34	6.35
C25 C40	DN25...40	16	50.5	6.35
C50	DN50	16	64	6.35
D15 D20	1/2"...3/4"	16	25	4.75
D25 D32	1"...1-1/2"	16	50.5	6.35
D50	2"	16	64	6.35

VARIVENT®

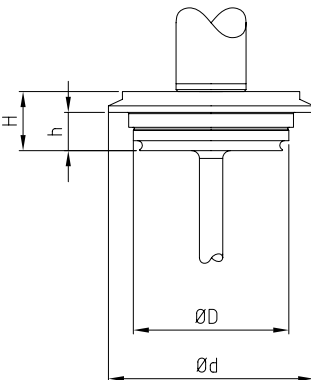

Connection	Nominal width	PN	ØD [mm]	Ød [mm]	H [mm]	h [mm]
V10 V15	DN10, DN15	25	31	52.7	20	13.65
V25 V32	DN25, DN32	25	50	66	18	12.30
V40 V50	DN40, DN50	16	68	84	18	12.30

Dimensions Process Connection (continued)

Union nut DIN 11851

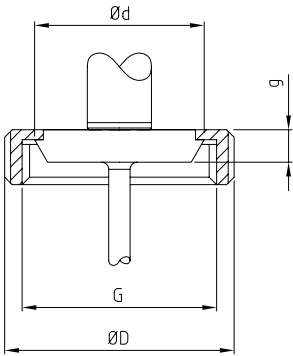

Connection	Nominal width	PN	Ød [mm]	G	ØD [mm]	g [mm]
U20	DN20	40	36.5	RD 44x6	54	8
U25	DN25	40	44	RD 52x6	63	10
U32	DN32	40	50	RD 58x6	70	10
U40	DN40	40	56	RD 65x6	78	10
U50	DN50	25	68.5	RD 78x6	92	11

Electrical Connection

Pt100 connection

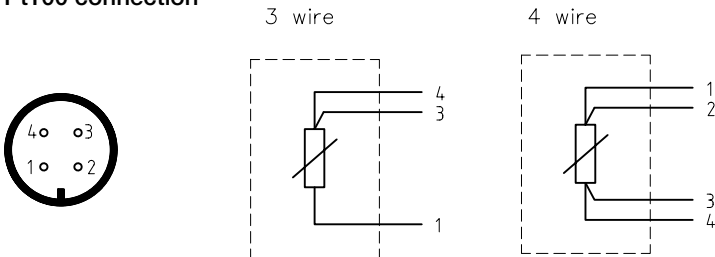

Transmitter connection

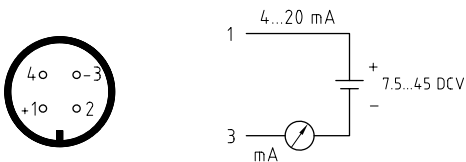

Pt100 connection DIN 43650

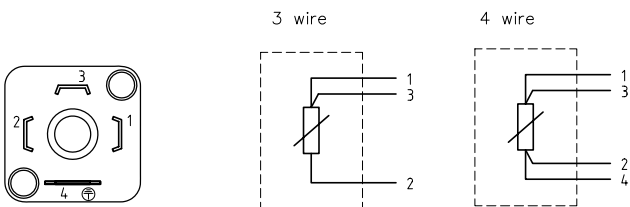

Transmitter connection DIN 43650

